

# COMPUTER-AIDED INJECTION MOLD DESIGN AND MANUFACTURE

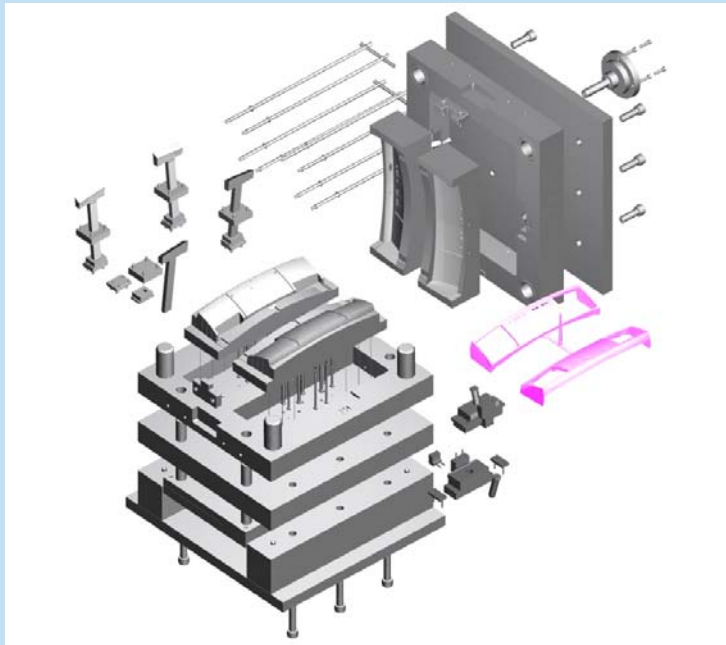

**J. Y. H. Fuh**  
**Y. F. Zhang**  
**A. Y. C. Nee**  
**M. W. Fu**

### About the book ...

**M**old making is an important sector in the precision engineering industry since molded parts represent more than 70% of the consumer products ranging from computers, home appliances, medical devices, to automobiles, etc. While CAD/CAM technology has found a wide range of applications in the many areas of engineering, its applications to mold design and manufacturing have been relatively limited. This book, containing more than 255 illustrations, is written for the aim of reporting the latest research and development achieved in automating plastic injection mold (for plastic) and die casting mold (for metal) design and manufacture. It is hoped to promote the use of computer-aided injection mold design systems and stimulate greater R&D efforts in this critical area.

### About The Authors

*Dr. Jerry Ying Hsi Fuh* is an Associate Professor at the Department of Mechanical Engineering, National University of Singapore (NUS). Dr. Fuh received his Ph.D. and M.S. degrees from the University of California at Los Angeles (UCLA). He is a registered Professional Engineer from California, USA and a Member of SME and ASME. His research interests include rapid prototyping processes (RP) and materials, distributed CAD/CAM, and plastic injection mould design. He has published one book on RP and more than 160 technical papers in various international journals and conferences.

*Dr. Yun Feng Zhang* - He received his B.Eng. from Shanghai Jiao Tong University, China in 1985 and Ph.D. from the University of Bath, UK in 1991. He is currently an Associate Professor at the Department of Mechanical Engineering, NUS. His research interests include reverse engineering, multi-axis tool path planning, CAPP and scheduling. He is a Senior Member of SME.

*Prof. Andrew Yeh Ching Nee* - He received his D.Eng. and Ph.D. from UMIST in 1973 and 2002. He is currently a Professor at the Department of Mechanical Engineering, NUS. He has published two books and over 430 papers in the area of manufacturing engineering. His research interests include: application of AI techniques in manufacturing, virtual manufacturing, computer-aided die, mold and fixture design. He has been an Active Member of CIRP and SME Fellow since 1990. He holds editorial appointment of 14 international refereed journals.

*Dr. Ming Wang Fu* - He received his B.Eng. and MEng. from Northwestern Polytechnic University, China, and Ph.D. in Mechanical Engineering from NUS. He is currently a Research Fellow at the Singapore Institute of Manufacturing Technology. He is a Senior Member of SME. His research interests include metal forming technology, preliminary design of complex product/system, CAE, computer-aided stamping die and plastic injection mold design, and integrated CAD/CAPP/CAM.